

# V-TAC

Meaningful Innovation.

WEEE Number: 80133970

## INSTRUCTION MANUAL WIFI SPIKE LIGHT

### TECHNICAL DATA

MODEL	VT-5167	VT-5168
POWER	7W	7Wx3
MODULE POWER	5.2W	5.2Wx3
VOLTAGE	AC:220-240V, 50/60Hz	
MODULE VOLTAGE	DC:24, 7V	DC:24, 7V
CURRENT	21MA	21MA
MODULE CURRENT	52MA	52MA
LUMEN	520LM	520LMx3
MODULE LUMEN	700LM	700LMx3
BEAM ANGLE	70°	70°
MODULE BEAM ANGLE	SPHERE 360°	SPHERE 360°
DIMENSION	232x140mm	232x140mm
LIFE SPAN	25,000 Hours	25,000 Hours
BODY TYPE	PC	PC



**IP65  
RATING**

 **EU PLUG**



**02** YEAR  
**WARRANTY\***

### INTRODUCTION & WARRANTY

Thank you for selecting and buying V-TAC SMART LED Lighting. V-TAC will serve you the best. Please read these instructions carefully before starting the installation and keep this manual handy for future reference. If you have any other query, please contact our dealer or local vendor from whom you have purchased the product. They are trained and ready to serve you at the best. The warranty is valid for 2 years from the date of purchase. The warranty does not apply to damage caused by incorrect installation or abnormal wear and tear. The company gives no warranty against damage to any surface due to incorrect removal and installation of the product. The products are suitable for 10-12 Hours Daily operation. Usage of product for 24 Hours a day would void the warranty. This product is warranted for manufacturing defects only.



#### MULTI-LANGUAGE MANUAL QR CODE

Please scan the QR code to access the manual in multiple languages.



**FR**  
Cet appareil, ses accessoires et cordons se recyclent

À DÉPOSER EN MAGASIN



À DÉPOSER EN DÉCHÈTERIE



OU

Points de collecte sur [www.quefairedemesdechets.fr](http://www.quefairedemesdechets.fr)  
Privilégiez la réparation ou le don de votre appareil !

---

## SAFETY WARNING

1. Please make sure to turn off the power before starting the installation.
2. Installation must be performed by a qualified electrician
3. Do not exert external force or throw on the lamp.
4. Lamps should be stored in cool/dry place. Always make sure the environment is clean before installing the lamp.
5. Do not discard the lamps with regular trash. Lamps are made with electronic components and should be properly disposed at designated locations with unified treatment like traditional electronic equipment.

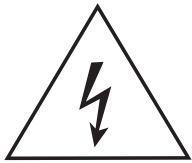

Caution, risk of electric shock.



This marking indicates that this product should not be disposed of with other household wastes.

### Note:

1. This device requires Wi-Fi Frequency 2.4Ghz
2. Operating frequency (maximum transmitted power) 2400MHz -2483.5MHz (20dBm)

### APP INSTALLATION

Step 2: Scan the given QR code, or download "Smart Life" from the App Store (iOS) or the Google Play Store (Android).



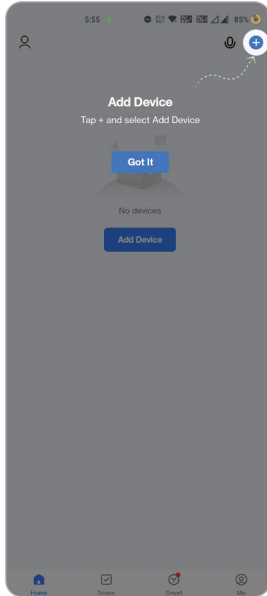

4. Enable Bluetooth and Home Wifi for the device to access your wifi connection for pairing

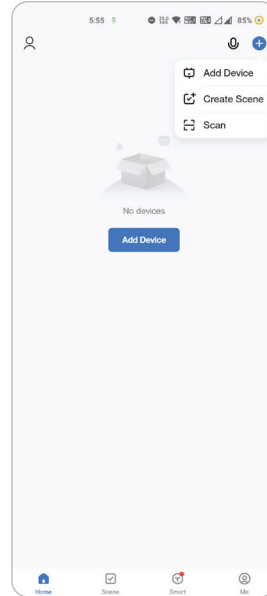

5. Click "Add a device" or "+" in the top right corner.

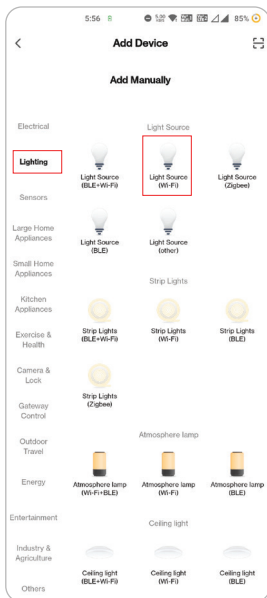

6. Click on the Lighting choose "Light Source (Wi-Fi)"

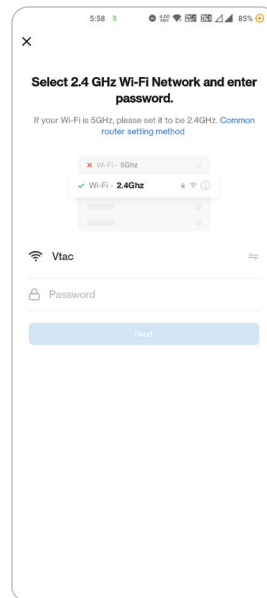

7. Select 2.4GHz Wi-Fi network and enter the password

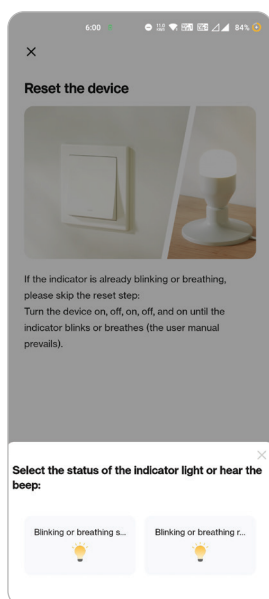
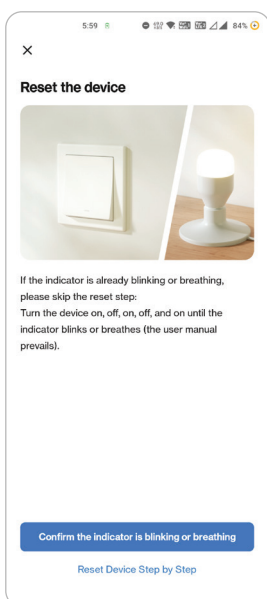

Step 10:

V-TAC Smart Light Bulb offers two types of pairing modes:

- 1) EZ Mode - Light flashes rapidly
- 2) AP mode - Slow Flash or long brightness

How to enable/reset the smart bulb into pairing mode -

Step 1: Switch ON the bulb, if the light is flashing rapidly the device is in EZ mode. Please proceed to pairing the smart device with the App. If not please follow Step 2.

Step 2: Switch the bulb OFF-ON repeatedly 3 times with short intervals of less than 2 seconds. Light flashes rapidly indicating the device has entered pairing mode. Please proceed to pairing the smart device with the App.

Note: Each time you switch the device OFF-ON repeatedly 3 times with short intervals of less than 2 seconds the pairing mode of the device alternatively switches between EZ mode and AP mode.

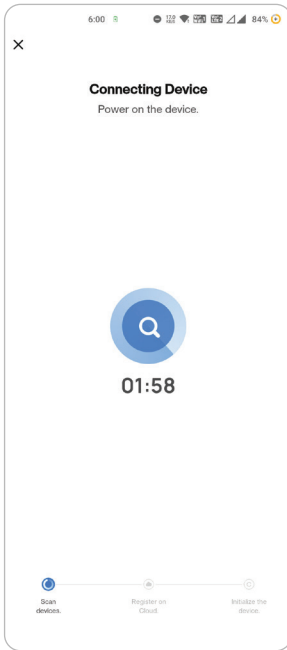

Step 8: Once you have successfully completed step 10, you will be redirected to below page, where the App searches, registers and initializes the device(lamp) (ref image below).

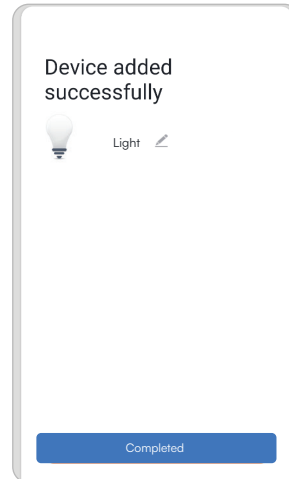

Step 9: Once your device is successfully added, rename the device to your preference.

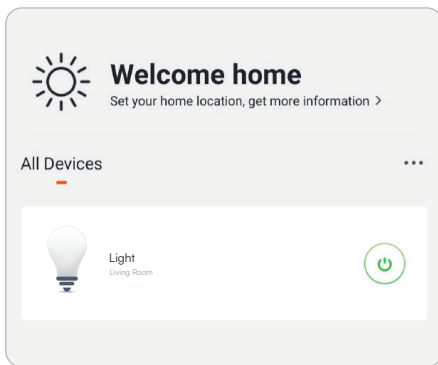

Step 10: You can now start controlling your device with the App. Tap the device name on the home page to enter the controls and features of the device.

Step 11: After successfully pairing the lamp with the app, you can start controlling multiple features of the lamp through your mobile— on/off switch, changing the colour temperature, timing & schedules, dimming options, and more.

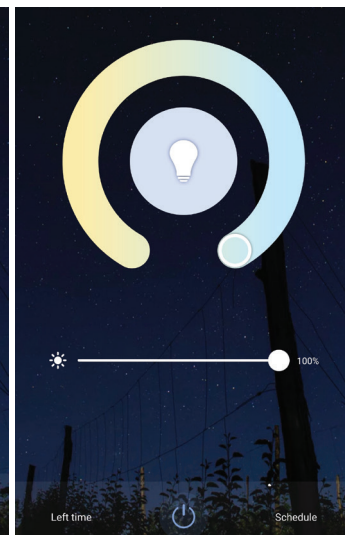
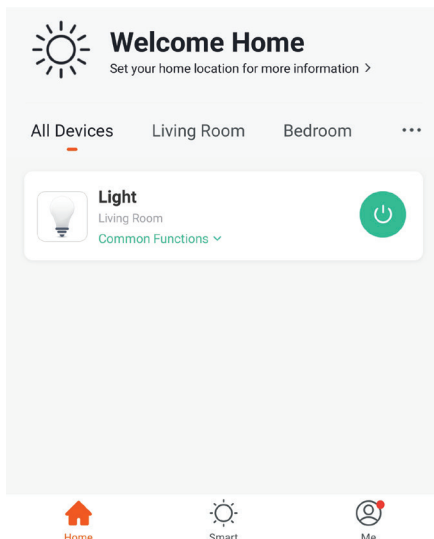

# GOOGLE HOME SETTINGS

## Set up

Set up new devices or add existing devices and services to your home

### New devices

-  **Set up new devices**  
Google Home, smart displays and devices labelled 'Made for Google' such as C by GE smart bulbs

### Works with Google

-  **Have something already set up?**  
Link your smart home services such as Philips Hue and TP-Link

## Smart Life

- Step 5: Sign In with your Smart Life Login credentials to Link the Smart Life device.
- Step 6: Tap on Authorize in order to proceed to linking the device.

 +1





[Forgot Password](#) [Help](#)



Google will be able to:  
Receive your public profile  
Control your devices over internet

## Step 7

- Account will now be linked, please stay on the page you will be redirected in few seconds to select the device to add to your home.
- Select the device and tap on Next as show in image b.

[Done](#)  [assistant.google.com](#) 

a. **Account is now Linked**

b.  **Choose device**

  
home light  
Light

## Choose a home

You will be able to control the devices and services in this home.

- Smart-Home
- Office
- Smart Home
- Create another home

[NEXT >](#)

Step 8: Select the Home where you would like to add the Smart Life under. (Or) you can create a New home in order to add the Smart Life to it.

Step 9: You have successfully added Smart Life device to your Google Assistant App.

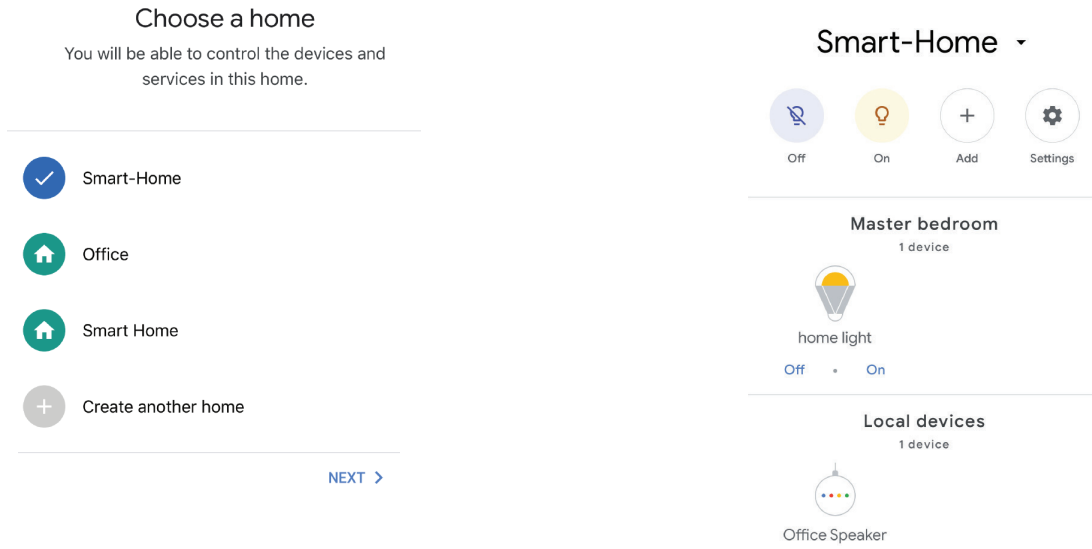

Step 10

a. You can turn the Lamp On/OFF by tapping on On/Off options as shown below. (OR) You can tap on the Smart Lamp.

b. You will be redirected to page(as shown in image b) where you can control the lights "Power and Dimming functionality".

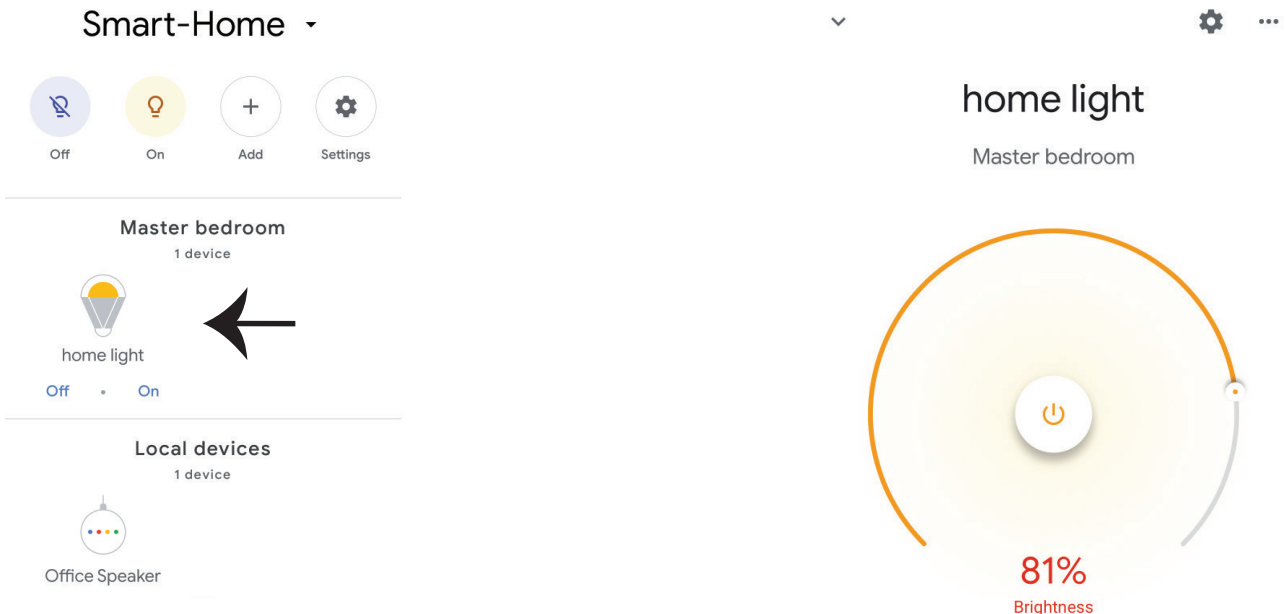

## Google Commands

Now, you can control your smart device using voice commands on Google Assistant. Below are a few commands you can use:

*Ok, Google, turn on/off bedroom light,*

*Ok, Google, turn on/off Hall light.*

## THINGS TO REMEMBER BEFORE STARTING INSTALLATION

1. Smart Life App & Google Assistant App Ok, Google, set bedroom light to warm white.
2. Make sure you have Google Assistant Device
3. Smart Device - Lamp
4. Stable Wifi network

## ALEXA SETTINGS

Step 1: Install the Amazon Alexa app via the App Store (iOS) or the Play Store (Android) and register. If you already have an existing account with Amazon Alexa, please proceed to logging in.

Step 2: Once you are on the Amazon Alexa home page, tap on the lower right icon — where the arrow is pointed — to add a new device and skill.

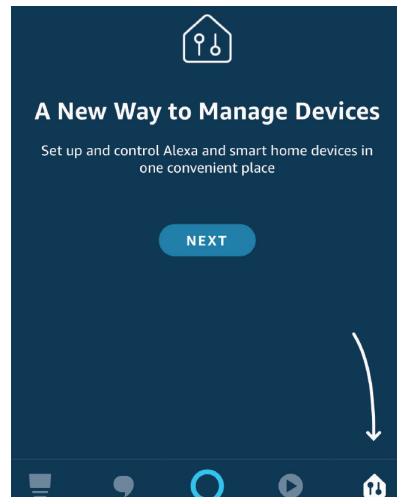
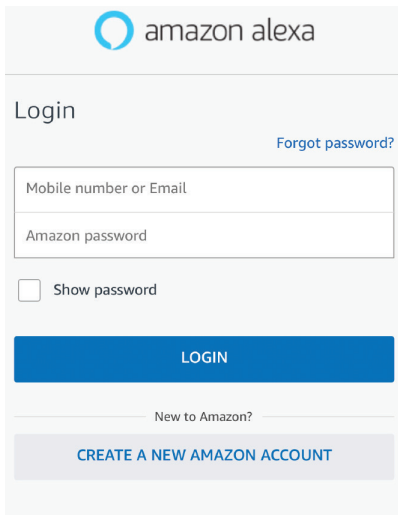

Step 3: Tap on  settings and tap on “skills and games” as shown below.

Step 4: Search for ‘Smart Life’ on the “Skills & Games” page as shown below.

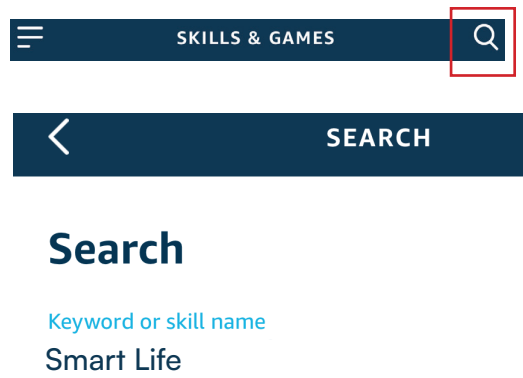
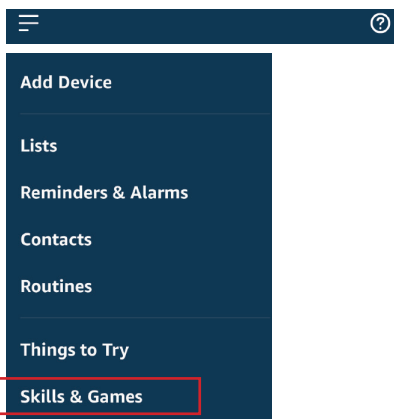

Step 5: Enable the Skill

Step 6: Enter your Smart Life login ID and password and tap on “Link Now”

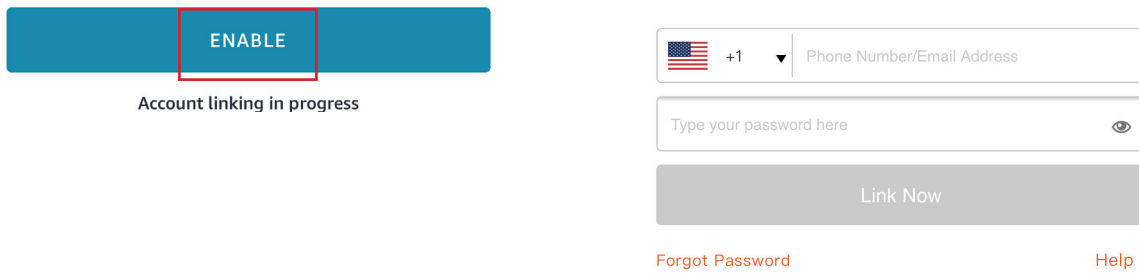

Step 7: Once you tap on Link Now, you will be redirected to a new page requesting for authorization(Ref Image below). Tap on “Authorize”

Step 8: You will receive confirmation of the account being linked successfully (Ref Image below)

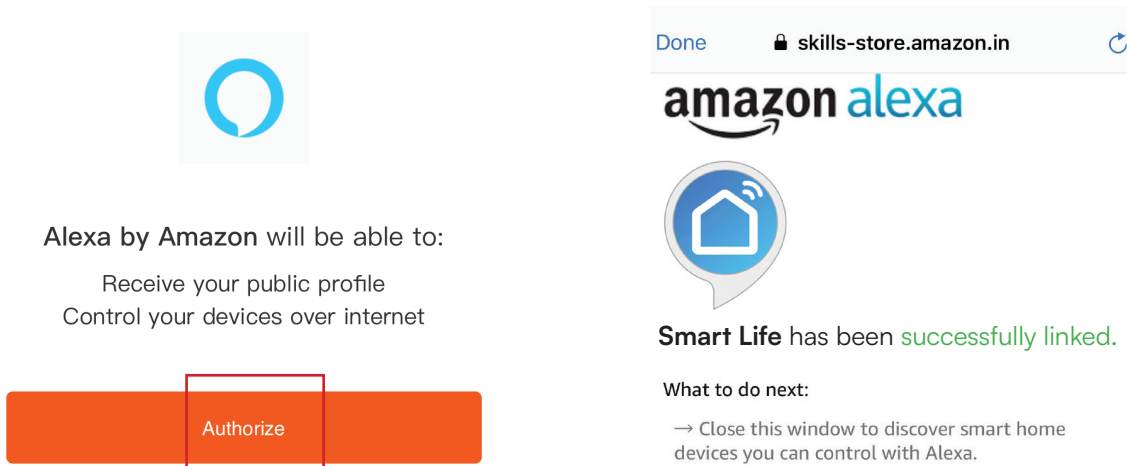

Step 9: Discover your smart device on Alexa. Once you have enabled the skill

A) You can use voice command “Alexa discover devices” to the Alexa device which you have.

B) To add device manually on home page tap on  and tap on Add device , select the device which you are adding and tap on discover device.

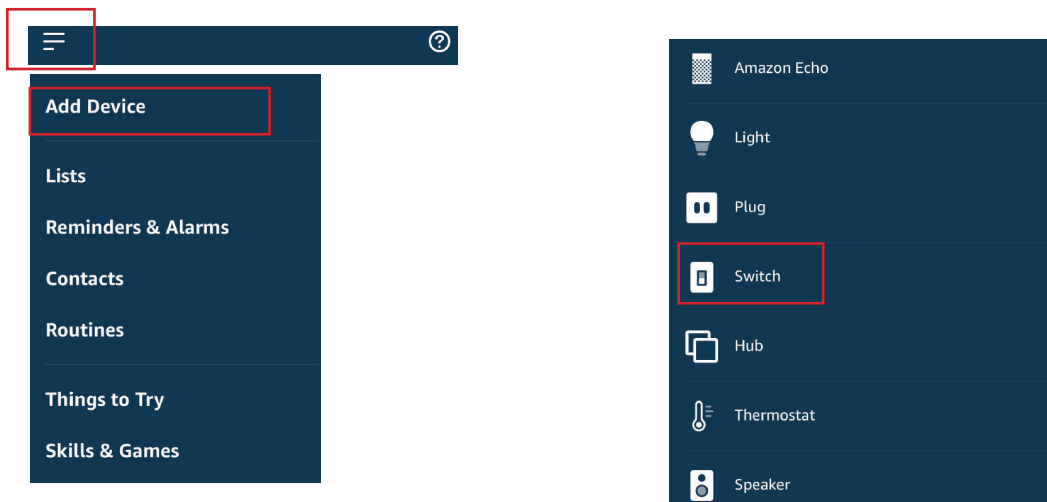

Note: Discovering the device must be done every time the device’s name is changed on the app.



---

## ALEXA COMMANDS

Now, you can control your smart device using voice commands on Alexa.  
Below are a few commands you can use:

*Hi Alexa, Turn On/Off bedroom light.*

*Hi Alexa, Turn On/Off Hall Light.*

## THINGS TO REMEMBER BEFORE STARTING INSTALLATION

1. Smart Life App & Amazon Alexa App
2. Make sure you have Amazon Alexa Device(including Echo, Echo Tap, or Echo Dot)
3. Smart Device - Lamp
4. Stable Wifi network



IN CASE OF ANY QUERY/ISSUE WITH THE PRODUCT, PLEASE REACH OUT TO US AT: [SUPPORT@V-TAC.EU](mailto:SUPPORT@V-TAC.EU)  
FOR MORE PRODUCTS RANGE, INQUIRY PLEASE CONTACT OUR DISTRIBUTOR OR NEAREST DEALERS.  
V-TAC EUROPE LTD. BULGARIA, PLOVDIV 4000, BUL.L.KARAVELOW 9B

IN CASE OF ANY QUERY/ISSUE WITH THE PRODUCT, PLEASE REACH OUT TO US AT: [SUPPORT@V-TAC.EU](mailto:SUPPORT@V-TAC.EU)  
FOR MORE PRODUCTS RANGE, INQUIRY PLEASE CONTACT OUR DISTRIBUTOR OR NEAREST DEALERS.  
V-TAC WEST EUROPE LTD. GROUND FLOOR, 71 LOWER BAGGOT STREET, DUBLIN 02, IRELAND DO2 P593

IN CASE OF ANY QUERY/ISSUE WITH THE PRODUCT PLEASE REACH OUT TO US AT  
[SUPPORT@VTACEXPORTS.COM](mailto:SUPPORT@VTACEXPORTS.COM) V-TAC HOUSE, KELPATRICK ROAD, SLOUGH, BERKSHIRE, SL1 6BW, UK.

---

---

## STEPS TO DISSASSEMBLE THE LAMP (ONLY FOR MARKET SURVEILLANCE AUTHORITY)

### DISSASSEMBLING DIAGRAM

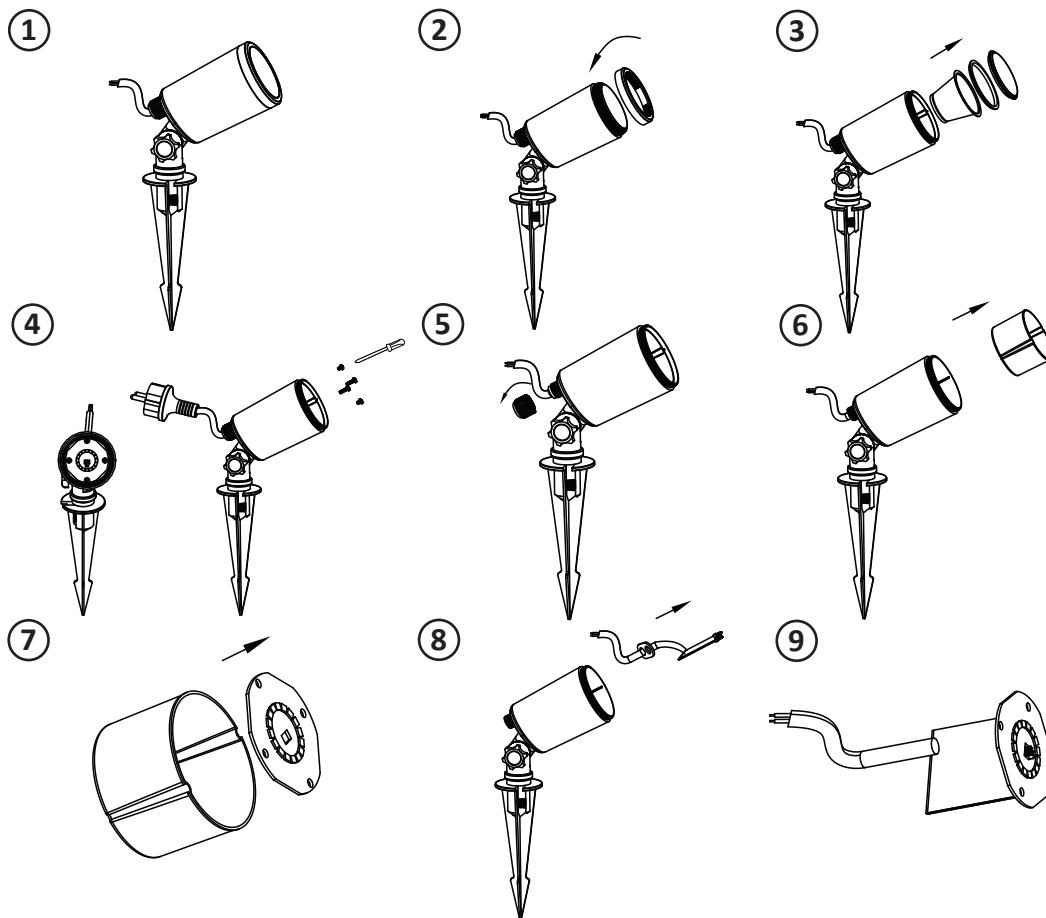

### HOW TO DISSASSEMBLE THE DEVICE

1. Power off and take out a whole lamp
2. Unscrew the cover anticlockwise (there is glue on the thread of the cover, which needs to be opened with greater force)
3. Take out the lampshade, waterproof rubber ring, reflective bowl and other parts
4. Unscrew the four screws fixing the light source plate with a screwdriver
5. Unscrew the waterproof connector cap on the back of the light anticlockwise
6. Take out the waterproof joint cap and waterproof silicone rubber ring along the stripping end of the power cord
7. Take out the aluminum lamp cup with the power board
8. Take out the light source plate from the aluminum lamp cup
9. Take out the drive board with power cord from the lamp cup
10. Connect the light source board and the drive board (note that the pin should not be inserted reversely, and the arrow symbol on the light source board points to the side of the drive board where the components are attached)

**Note: Dissassembling the Lamp will Void the Warranty**

---